

WA90-6A

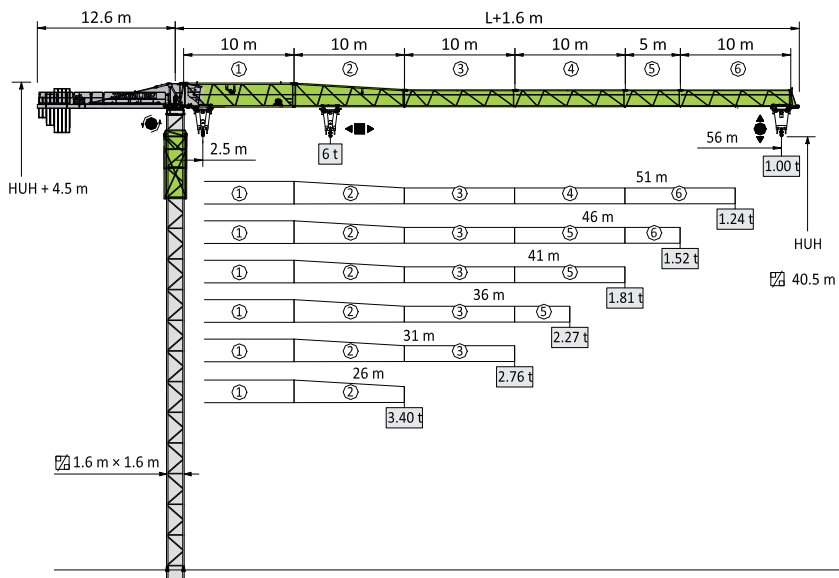

塔身—反力&附着 / Mast – Reactions & Anchorages / Mast – Fundament Ecklasten & Verankerungen

1.6m – E2

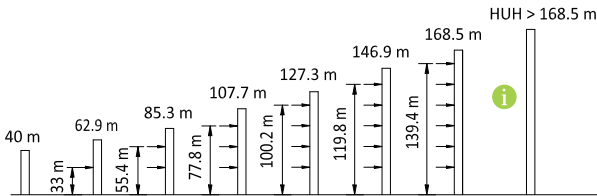
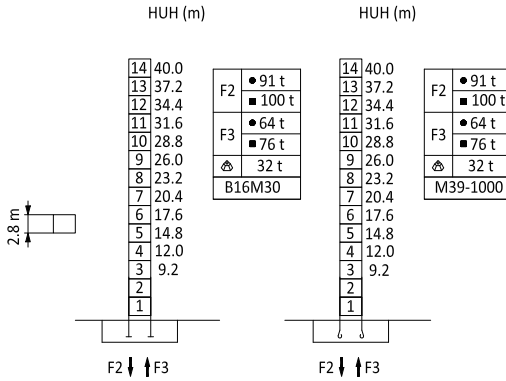















/ Counter-jib ballast / Gegenballast **平衡重**









高度 (m)	2.0 t	1.3 t	数量 (t)	PHZ2000Q	PHZ1300N
56.0	6	2	14.6		
51.0	5	2	12.6		
46.0	6	0	12.0		
41.0	4	2	10.6		
36.0	4	1	9.3		
31.0	3	2	8.6		
26.0	2	2	6.6		

Load diagrams / Lastkurven / 起重性能





 — 

吊钩间距 m		m / t	16.0	18.0	21.0	23.0	26.0	28.0	31.0	33.0	36.0	38.0	41.0	43.0	46.0	48.0	49.0	51.0	53.0	56.0
56.0		2.5-25.5/3.0	3.00	3.00	3.00	3.00	2.93	2.67	2.34	2.16	1.92	1.78	1.61	1.50	1.36	1.28	1.24	1.16	1.09	1.00
		2.5-14.2/6.0	5.21	4.52	3.75	3.35	2.88	2.61	2.29	2.10	1.87	1.73	1.55	1.45	1.30	1.22	1.18	1.11	1.04	0.95
51.0		2.5-26.6/3.0	3.00	3.00	3.00	3.00	3.00	2.81	2.47	2.28	2.03	1.89	1.70	1.59	1.45	1.36	1.32	1.24		
		2.5-14.8/6.0	5.46	4.75	3.95	3.53	3.03	2.76	2.42	2.23	1.98	1.84	1.65	1.54	1.39	1.30	1.26	1.19		
46.0		2.5-27.5/3.0	3.00	3.00	3.00	3.00	3.00	2.94	2.58	2.38	2.13	1.98	1.79	1.67	1.52					
		2.5-15.3/6.0	5.68	4.95	4.11	3.68	3.16	2.88	2.53	2.33	2.07	1.93	1.73	1.62	1.47					
41.0		2.5-27.8/3.0	3.00	3.00	3.00	3.00	3.00	2.97	2.61	2.41	2.16	2.01	1.81							
		2.5-15.4/6.0	5.75	5.00	4.16	3.73	3.20	2.92	2.56	2.36	2.10	1.95	1.76							
36.0		2.5-28.9/3.0	3.00	3.00	3.00	3.00	3.00	3.00	2.75	2.54	2.27									
		2.5-16.0/6.0	6.00	5.24	4.36	3.91	3.36	3.07	2.69	2.48	2.22									
31.0		2.5-29.0/3.0	3.00	3.00	3.00	3.00	3.00	3.00	2.76											
		2.5-16.1/6.0	6.00	5.26	4.38	3.92	3.38	3.08	2.71											
26.0		2.5-26.0/3.0	3.00	3.00	3.00	3.00	3.00													
		2.5-16.2/6.0	6.00	5.29	4.40	3.95	3.40													



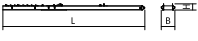
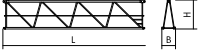
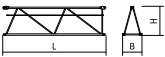
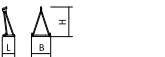
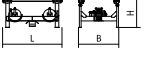

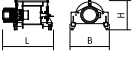
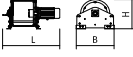

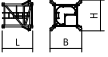

/ Mechanisms / Triebwerke 传动机构

380 V (± 10 %) 50 Hz							kW		
	H25FC15-440	t	0.8	3	1.6	6	25	440 m 	
		m/min	100	40	50	20			
	S75C6A-150LB12/16A	r/min	0 - 0.8				7.5		
	T30FC60-b(D)	m/min	0 - 100				3.0		
			35.5 kW						

运输单元 / Dimensions and weight / Abmessungen und Gewicht

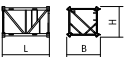
上装 / Slewing crane part / Drehender Kranteil		L (m)	B (m)	H (m)	kg (±5%)	
平衡臂 Counter-jib Gegenausleger		11.83	1.15	0.61	2590	
起重臂节 Jib section Auslegerelement		①	10.13	0.99	2.38	1690
		②	10.18	0.98	2.23	1200
		③	10.17	0.98	1.62	960
		④	10.16	0.98	1.60	750
		⑤	10.15	0.98	1.57	480
		⑤	5.16	0.98	1.57	270
		⑦	1.87	0.98	1.77	140
载重小车 Trolley Laufkatze		2.03	1.67	0.90	280	
吊钩 Pulley block Hubflasche		0.93	0.36	1.54	290	
司机室 Cabin Kabine		2.08	1.25	2.25	500	
起升机构 Hoisting mechanism Hubwerk		H18FC13-400P	1.73	0.97	0.77	714
变幅机构 Trolleying mechanism Katzfahrwerk		T30FC60-b	1.01	0.73	0.57	350
回转总成 Slewing assembly Drehteile		 1.6 m	1.74	1.83	2.86	3020

□

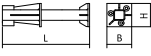
塔身 / Crane tower / Kranturm			L (m)	B (m)	H (m)	kg (±5%)
过渡节 Transition section Übergangsstück		 1.6 m - S16A5	2.08	2.14	2.80	1130
爬升架 Climbing tower section Kletterturmstück		 1.6 m - TC16P40	5.94	2.08	2.38	2640
标准节 Tower section Turmstück		 1.6 m - E2C	2.80	1.67	1.67	777
		 1.6 m - EQ7C	2.80	1.67	1.67	899
		 1.6 m - EQ8B	2.83	1.69	1.67	1020
		 1.6 m - EQ9B	2.83	1.69	1.67	1020
支腿 Fixing angles Verankerungsfuss		B16M30	1.25	0.3	0.3	4x102